

First Cosmic Ray Results of the ATLAS Barrel Muon Spectrometer with Magnetic Field

Jörg v. Loeben* on behalf of the ATLAS Muon Collaboration
*Max-Planck-Institut für Physik, München, Germany

Abstract—The ATLAS experiment at the Large Hadron Collider (LHC) at CERN is currently being assembled to be ready to take first data in 2008. Its muon spectrometer is designed to achieve a momentum resolution of better than 10% up to transverse muon momenta of 1 TeV. The spectrometer consists of one barrel and two endcap superconducting air-core toroid magnets instrumented with three layers of precision drift chambers as tracking detectors and a dedicated trigger system. First results of the cosmic ray test of the barrel muon spectrometer with magnetic field are presented, including results of the calibration of the drift chambers and of the spectrometer alignment.

I. INTRODUCTION

The ATLAS muon spectrometer (see fig. 1) consist of three superconducting air-core toroid magnets instrumented with 1194 precision drift chambers—Monitored Drift Tube (MDT) chambers, complemented Cathode Strip Chambers (CSCs) in the extreme forward region—and 2264 trigger chambers—Resistive Plate Chambers (RPCs) in the barrel and Thin Gap Chambers (TGCs) in the endcaps [1]. The chambers are arranged in three layers which cover an active area of more than 5500 m² up to pseudo-rapidity values of $|\eta| < 2.7$ (trigger chamber coverage extends to $|\eta| < 2.4$). Individual chamber sizes vary from 1 m² to 11 m². The magnets provide an average field integral of 3 Tm in the barrel and 5 Tm in the endcap region, with a typical path length of 7 m.

The muon spectrometer has been designed for stand-alone operation with a momentum resolution of 2–3% for transverse momenta below 200 GeV and better than 10% up to 1 TeV. To achieve the desired momentum resolution, the precision chambers must reconstruct track points with an accuracy of better than 50 μ m, including uncertainties from the misalignment of chambers at distances of 5–13 m. A system of more than 12000 optical sensors continuously monitors the deformations of the precision chambers and their relative positions within each layer and from layer to layer and connects them to a reference frame on the toroid coils. The data are used for alignment corrections in the reconstruction with an accuracy of 30 μ m in the bending plane.

II. TESTS AND MEASUREMENTS WITH MAGNETIC FIELD

A complete system test of the ATLAS barrel muon spectrometer including precision and trigger chambers, the optical alignment system, the central trigger processor and the data acquisition system took place in November 2006 when the barrel toroid magnet was operated at its nominal field for the

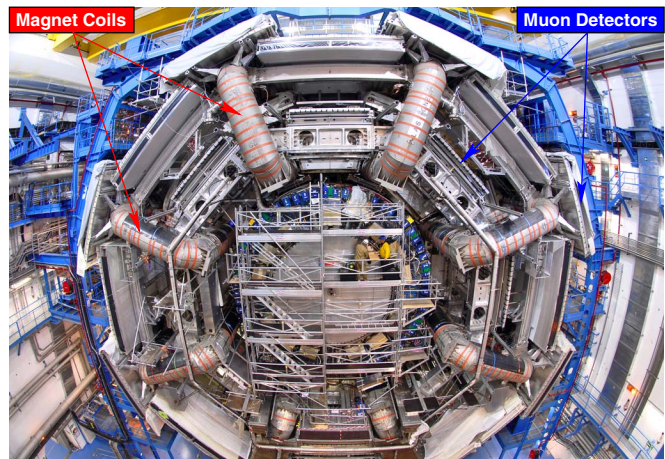

Fig. 1. Front view of the barrel part of the ATLAS detector in November 2006

first time. 13 MDT chambers triggered by 9 RPCs of the lower barrel region participated in the data taking with cosmic-rays, see. fig. 2. We report preliminary results of the spectrometer deformations, recorded with the optical alignment system and of measurements with the MDT chambers. The performance of the RPC trigger chambers during the test is described in [2], the Level 1 trigger in [3].

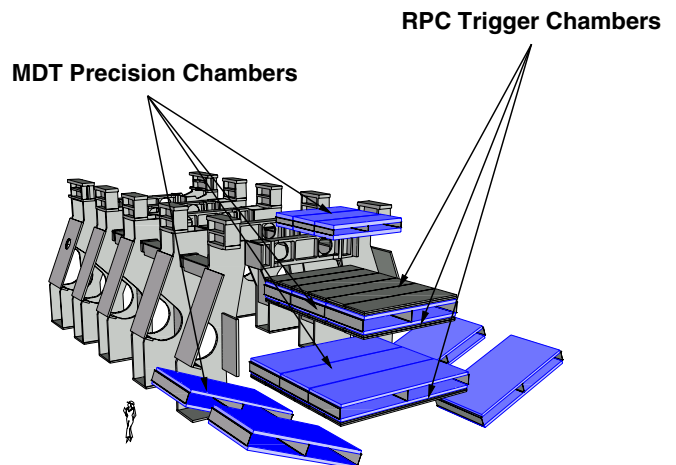

Fig. 2. Cut-away view of the ATLAS detector, showing only the 13 muon stations participating in the November 2006 cosmic-ray data taking with magnetic field

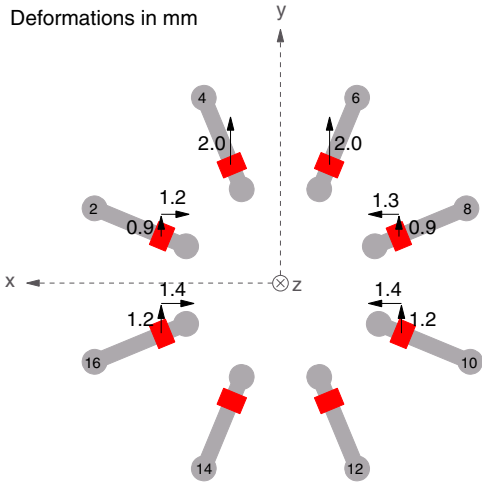

Fig. 3. Deformations of the barrel toroid at full field

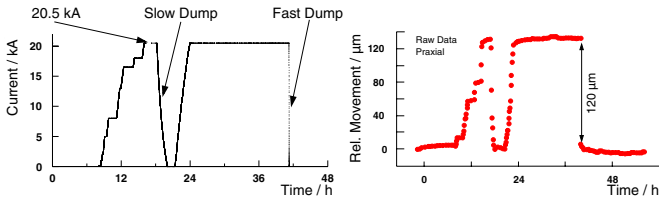

Fig. 4. Left side: Ramping procedure of the magnet on 17th and 18th of November 2006. Right side: Example of the movement of two MDT chambers with respect to each other (measured with the chambers optical alignment)

A. Movements in the Barrel Muon Spectrometer

The optical alignment system was used to measure the deformation of the barrel toroid during and the movements of the precision chambers during the magnet operation. The data of 15% of all 5700 barrel sensors was recorded. The measured movements of the magnet coils of a magnitude of 1–2 mm at full field (cp. fig. 3) were in agreement with the calculations. As the two lower coils are fixed to the ground, the upper two coils moved about 2 mm upwards and the remaining coils ~ 1 mm upwards and ~ 1.5 mm inwards. The deformations of the toroid due to magnetic forces between the coils (in addition to deformations caused by ~ 500 t of instrumentation) was considered in the construction resulting in a round shape at full field.

The left side of fig. 4 shows the current through the magnet coils during 36 h of test. The magnet was ramped up to 8, 13, 18 and finally to its nominal current of 20.5 kA before performing a normal ramp down (slow quench). In the slow quench the stored energy of 1 GJ of the toroid is dumped over a period of 2 hours in resistors. The magnet was then ramped up again and operated at its nominal field for 17 hours before a fast quench was initialized, simulating the unexpected loss of superconductivity. In a fast quench the energy is dumped into the coils and the energy is absorbed in 3 minutes by evaporating the liquid helium.

As the muon chambers are mounted on or between the toroid coils, movements of the chambers themselves are to be expected. Fig.4 right shows the movement of two MDT

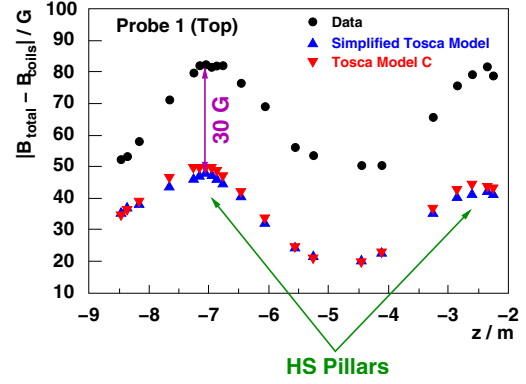

Fig. 5. Measured and simulated (simplified TOSCA & TOSCA C model) perturbations of the toroid field caused surrounding structures close to the outer MDT layer

chambers with respect to each other. Representative for other possible degrees of freedom, the relative distance between two chambers from the innermost layer is plotted. The movement follows the ramping procedure of the magnets (cp. fig. 4 left) and is in the order of a few hundred microns, well within the range of the optical sensors. The maximal recorded displacements were 0.8 mm in the plane of the chambers and 0.1 mm in radial direction r within the detector layers and accordingly 0.5 mm along the chambers and 2 mm in r between the three layers in the uppermost part of the spectrometer. The results underline the importance of the alignment corrections to reach the required precision in the muon momentum measurement as the movements are more than one order larger than the claimed accuracy for the reconstruction of the track points (better than $50 \mu\text{m}$).

B. Magnetic Field Map

To reach the desired resolution of the muon spectrometer the magnetic field map has to be known with an accuracy of $\Delta B < 10$ mT in the barrel. This accords to an relative knowledge of the bending power of

$$\frac{\Delta \int B dl}{\int B dl} < 4 \cdot 10^{-3}. \quad (1)$$

The barrel muon spectrometer is equipped with 1740 3-d hall sensors for the field map determination, which are mounted on the MDT chambers. During the time of the magnet test, 452 sensors were read out and in addition 5 movable probes were installed to scan the field on the outside of the spectrometer to determine the influence of nearby magnetic materials. Fig. 5 shows the result of one of these scans, the difference between the field from the coils and the total magnetic field with influences from the surrounding, magnetic access structures of the detector. The probe was moved along the spectrometers global z -axis close to the outer MDT layer. The red and blue triangles show the results of two simulations and the black dots represent the measurement. The variations of the perturbations are well simulated, but the model needs further refinement to describe the absolute scale correctly.

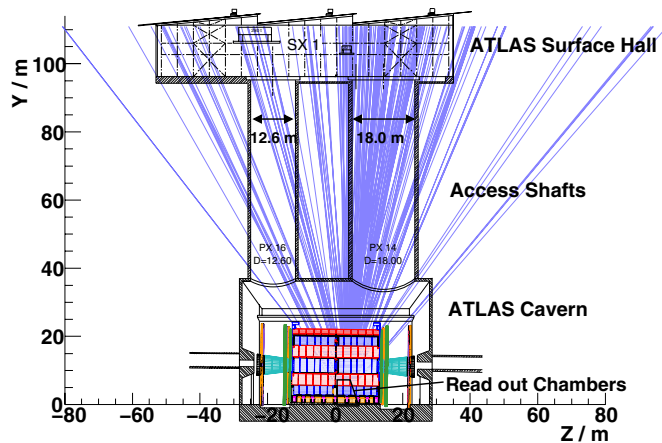

Fig. 6. Reconstructed origin of the cosmic muons

C. Data Taking with Cosmic Muons

During the magnet test in November 2006, about 700k events with and 500k events without magnetic field were recorded using the central trigger processor and the final read out system. The mean trigger rate was measured with 40 Hz consistent with the expected rate for the active detector area. Fig. 6 shows the origin of the cosmic muons extrapolated back to the surface above the detector from reconstructed, straight track segments in the MDT chambers from a run without magnetic field. It is consistent with the geometry of the two access shafts leading down to the ATLAS cavern with average angles of 10° for the large shaft (18 m in diameter) and -20° for the small one (12.6 m in diameter). The rate of muons entering from the small shaft is reduced compared to the ones from the large shaft, as they have to pass approximately 30 m of rock before entering the detector. In fig. 7 the angular distribution of positive and negative cosmic muons at the entry of the inner MDT layer is shown. The muons are clearly separated by the magnetic field according to their charge. The measured momentum distribution (cp. fig. 8) of the cosmic muons was found to be consistent with expectations. A crucial point is that the track reconstruction had no alignment

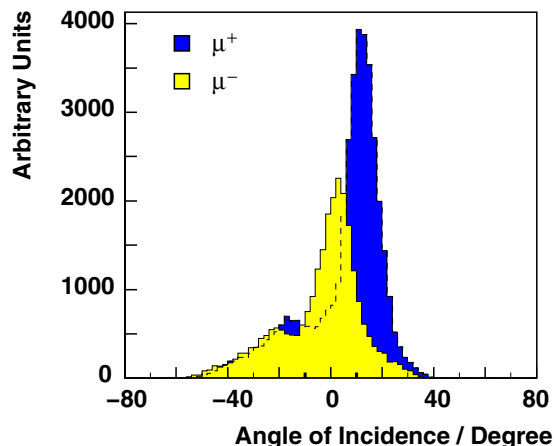

Fig. 7. Angle of incidence of the cosmic muons in the innermost MDT layer

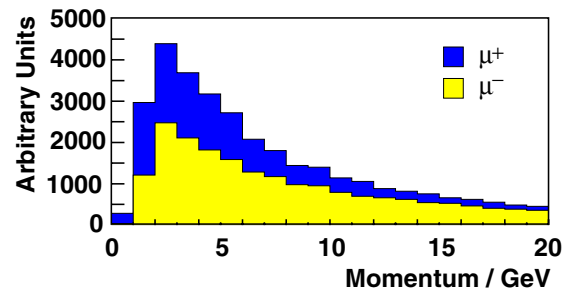

Fig. 8. Measured momentum distribution of the recorded cosmic muons in the cavern

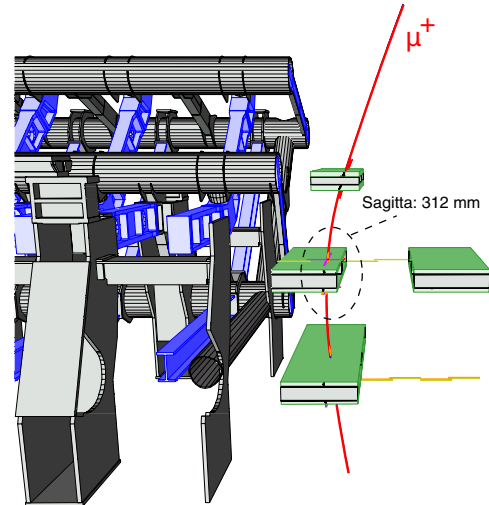

Fig. 9. Eventdisplay of a cosmic μ^+ with a measured momentum of 1.6 GeV

correction included. The system to align the chamber layers with respect to each other—the optical projective lines—was built to provide the best correction for the sagitta measurement for muons coming from the interaction point. For cosmics however, this accuracy is only in the order of 2 mm and thus not precise enough to improve the track reconstruction. The knowledge of the chamber positions at the time of data taking was also in the range of a few millimeters and gives thus a non-negligible error for measurements of higher muon momenta (cp. fig. 9). Hence, the muon type cannot be unambiguously distinguished anymore for muon momenta above ~ 20 GeV. The ratio of the number of positive to negative muons, which is caused by the asymmetric π^+/π^- production by the protons in the atmosphere could be measured with

$$N_{\mu^+}/N_{\mu^-} = 1.48 \pm 0.27 \text{ (prelim.)}, \quad (2)$$

and is in agreement with the PDG value of 1.1–1.4 [4].

To reach the required spatial resolution of $50 \mu\text{m}$, the space to drift-time relation (rt-relation) for the drift tubes of the MDT chambers has to be known with an accuracy of $20 \mu\text{m}$. The rt-relation is determined from the redundant measurement of the muon tracks in the drift tubes layers of a chamber using an iterative algorithm called autocalibration [5], [6]. The autocalibration zones, for which a common rt-relation can be obtained, are in general of the size of a single MDT chamber to provide a sufficient number and angular spread of muon

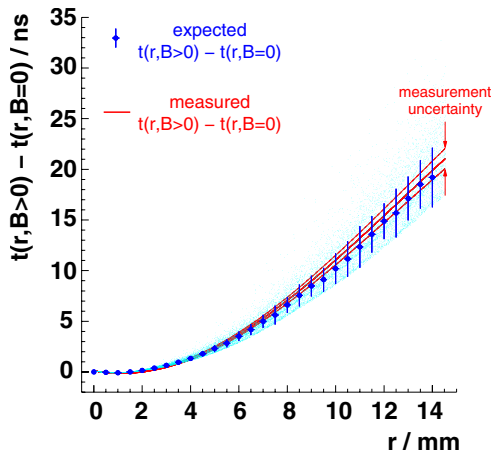

Fig. 10. Expected and measured change of the drift time in dependence of the drift radius for a chamber from the middle layer. The light blue dots represent the simulated time prolongation in all areas of the chamber. The spread of the dots is caused by the inhomogeneous field along the tubes. The filled circles with error bars are their mean value and RMS and the red line represents the measurement.

tracks necessary for the algorithm to converge. As the toroid field is not homogeneous across these zones, the r -relation has to be corrected for the effect of the magnetic field \mathbf{B} to reach the necessary precision: in test beam measurements a shift of the maximum drift time of $70 \text{ ns}/(\mathbf{B}^2/T^2)$ has been observed [7], [8], leading to deviations of up to $500 \mu\text{m}$ from the r -relation without magnetic field. A model [7], [8] for the dependence of the drift time $t(r, B)$ as a function of the magnetic field has been developed and yields an accuracy of better than 1 ns. Fig.10 shows a comparison of the expected change of the drift time and the measurements in the ATLAS toroidal magnetic field as a function of the drift radius. Due to low statistics, only the mean prolongation of the drift time could be compared. The filled circles with error bars in the figure represent the mean value and spread from all drift time changes along a chamber from the middle detector layer with simulated data. The line shows the difference in the drift time measured in a run with and one without magnetic field.

III. SUMMARY

A complete system test of the ATLAS barrel muon spectrometer was performed in November 2006. The barrel toroid was ramped up to its nominal field for the first time and the induced quench tests were successful as expected. The optical alignment system was used to record the deformations of the spectrometer which were proven to be consistent with the expectations. First preliminary results from the data taking with cosmic muons with and without magnetic field using the final read out system and trigger chain were presented. Preliminary analysis of the data includes the measurement of the momentum of the cosmic muons in the ATLAS cavern and the μ^+/μ^- ratio. The influence of the magnetic field on the drift time of the MDT chambers was found to be in very good agreement with the model expectations.

REFERENCES

- [1] ATLAS Muon Collaboration, ATLAS Muon Spectrometer Technical Design Report, CERN/LHCC/97-22, CERN (1997).
- [2] G. Chiodini et al., RPC cosmic ray tests in the ATLAS experiment, Nuclear Instruments and Methods in Physics Research Section A: Accelerators, Spectrometers, Detectors and Associated Equipment Volume 581, Issues 1-2, VCI 2007 - Proceedings of the 11th International Vienna Conference on Instrumentation, 21 October 2007, Pages 213-216. (<http://www.sciencedirect.com/science/article/B6TJM-4P9SN92-J/2/96475c7648bcbbdd09f60d8465ecc6b6>)
- [3] G. Aielli et al., The ATLAS level-1 trigger: Status of the system and first results from cosmic-ray data, Nuclear Instruments and Methods in Physics Research Section A: Accelerators, Spectrometers, Detectors and Associated Equipment Volume 581, Issues 1-2, VCI 2007 - Proceedings of the 11th International Vienna Conference on Instrumentation, 21 October 2007, Pages 476-481. (<http://www.sciencedirect.com/science/article/B6TJM-4PCGRR0-6/2/0032a39ef80427e786a5fece60b72d30>)
- [4] W.-M. Yao et al., J. Phys. G33,1 (2006).
- [5] M. Deile, Autocalibration: The Influence of Track Incident Angles and a New Method, ATLAS Note, ATL-MUON-2004-021
- [6] J. v. Loeben, An Efficient Method to Determine the Space-to-Drift-Time Relationship of the ATLAS Monitored Drift Tube Chambers, paper presented at this conference.
- [7] O. Kortner et al., NIM A572,1 (2007), 50–52.
- [8] C. Valderanis, PhD thesis, Technical University and Max-Planck-Institut für Physik, Munich, in preparation.