



# Development of a New L1 Muon Trigger System and New Readout Electronics for the ATLAS MDT Chambers at High LHC Luminosities

O. Kortner H. Kroha R. Richter P. Schwegler

Max-Planck-Institut für Physik, Munich



## Abstract

The planned upgrades of the Large Hadron Collider (LHC) towards higher luminosities require among other detector improvements also a significantly higher selectivity of the ATLAS level-1 muon trigger in order to efficiently reject the large low-momentum muon background without losing interesting signal events. The momentum resolution of the L1 muon trigger can be sufficiently improved by using the precision muon tracking detectors, the Monitored Drift Tube (MDT) chambers, in the trigger. This has the advantage that no new trigger chambers with higher spatial resolution need to be installed which is hardly possible for the largest part of the muon detector. A MDT chamber based muon trigger scheme has been developed and validated by simulation. Its implementation requires the replacement of the existing MDT on-chamber electronics which will also need higher radiation hardness and bandwidth. New readout chips in radiation hard technology and new frontend boards are under development.

## Long Term Planning for the LHC

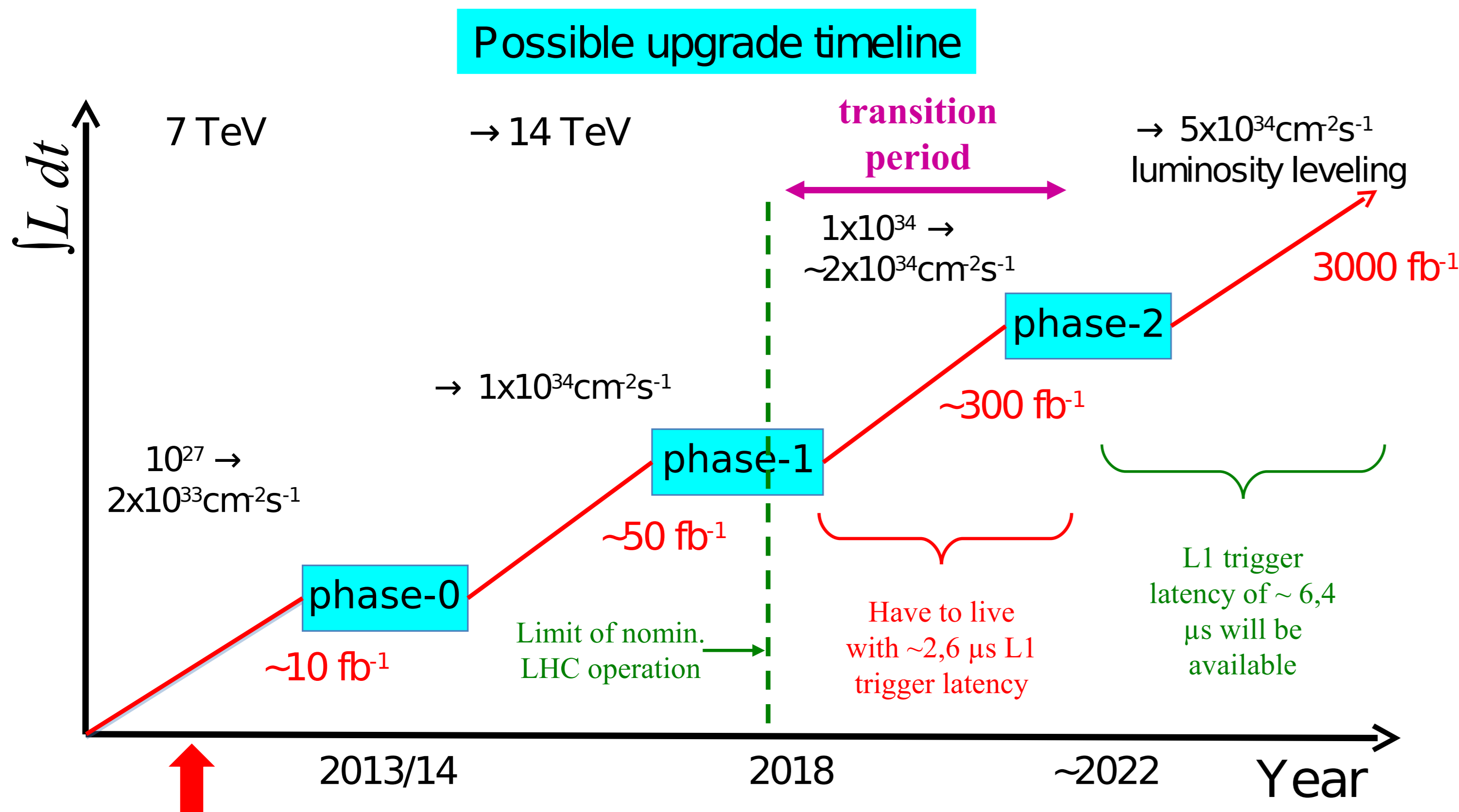

## Problem of the Muon Trigger: Diff. Cross Section vs. $p_T$

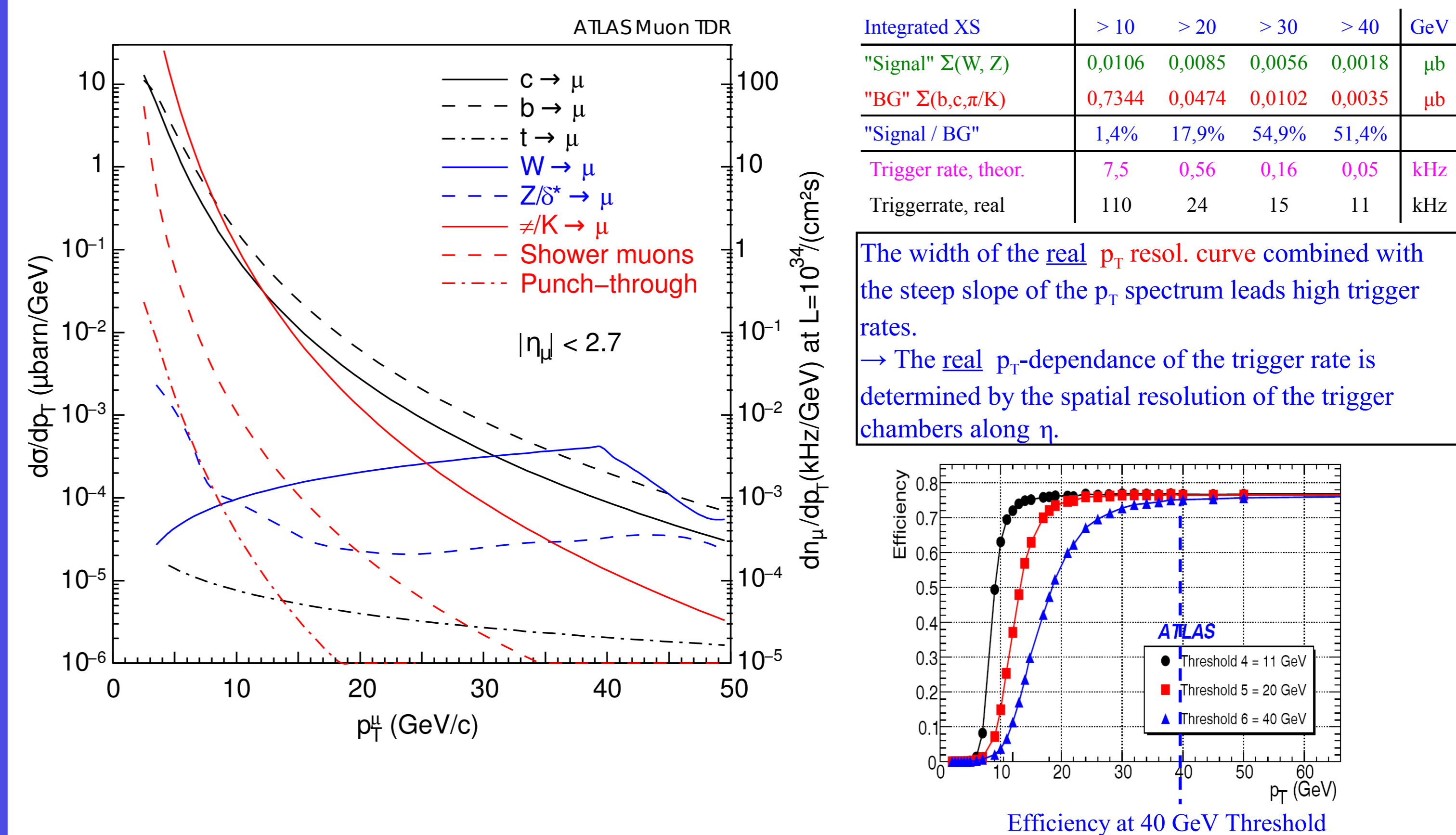

## Overview of L1 Muon Upgrade, Phase-1 & Phase-2

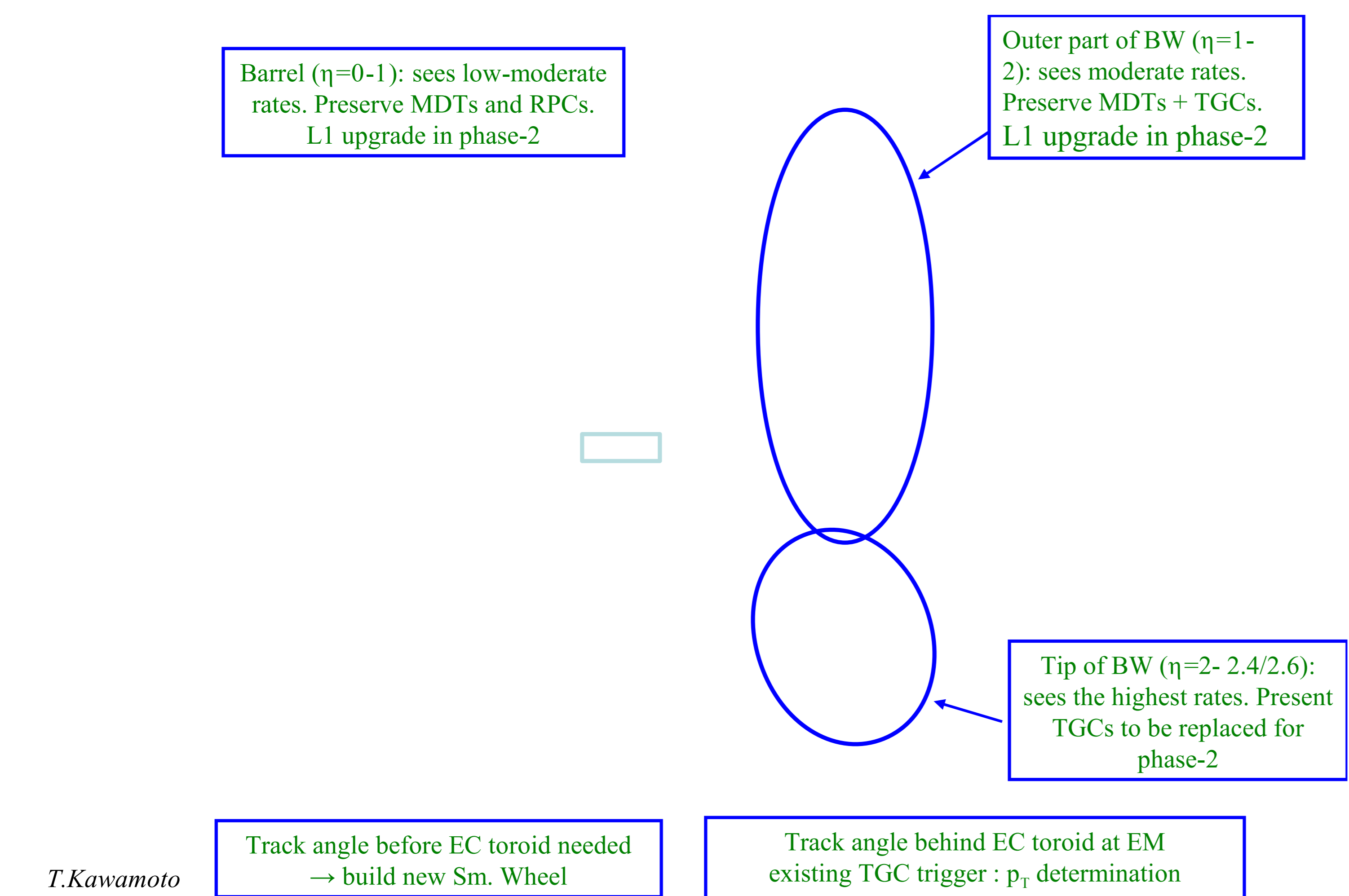

## A Tentative Recipe for Tube Readout (always read a fixed set of tubes)

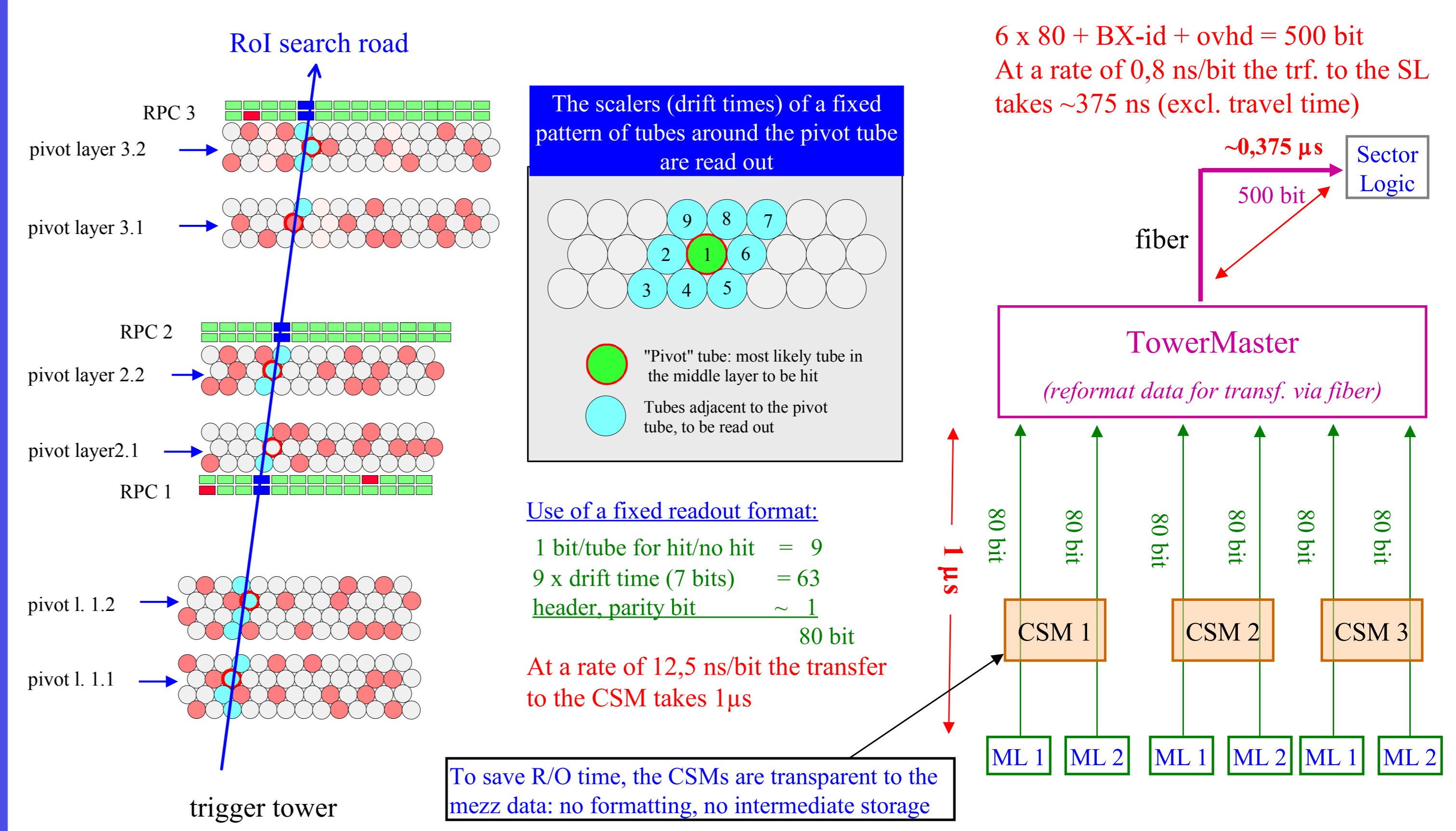

## Limitations of the L1 Trigger in the Present Muon Endcap

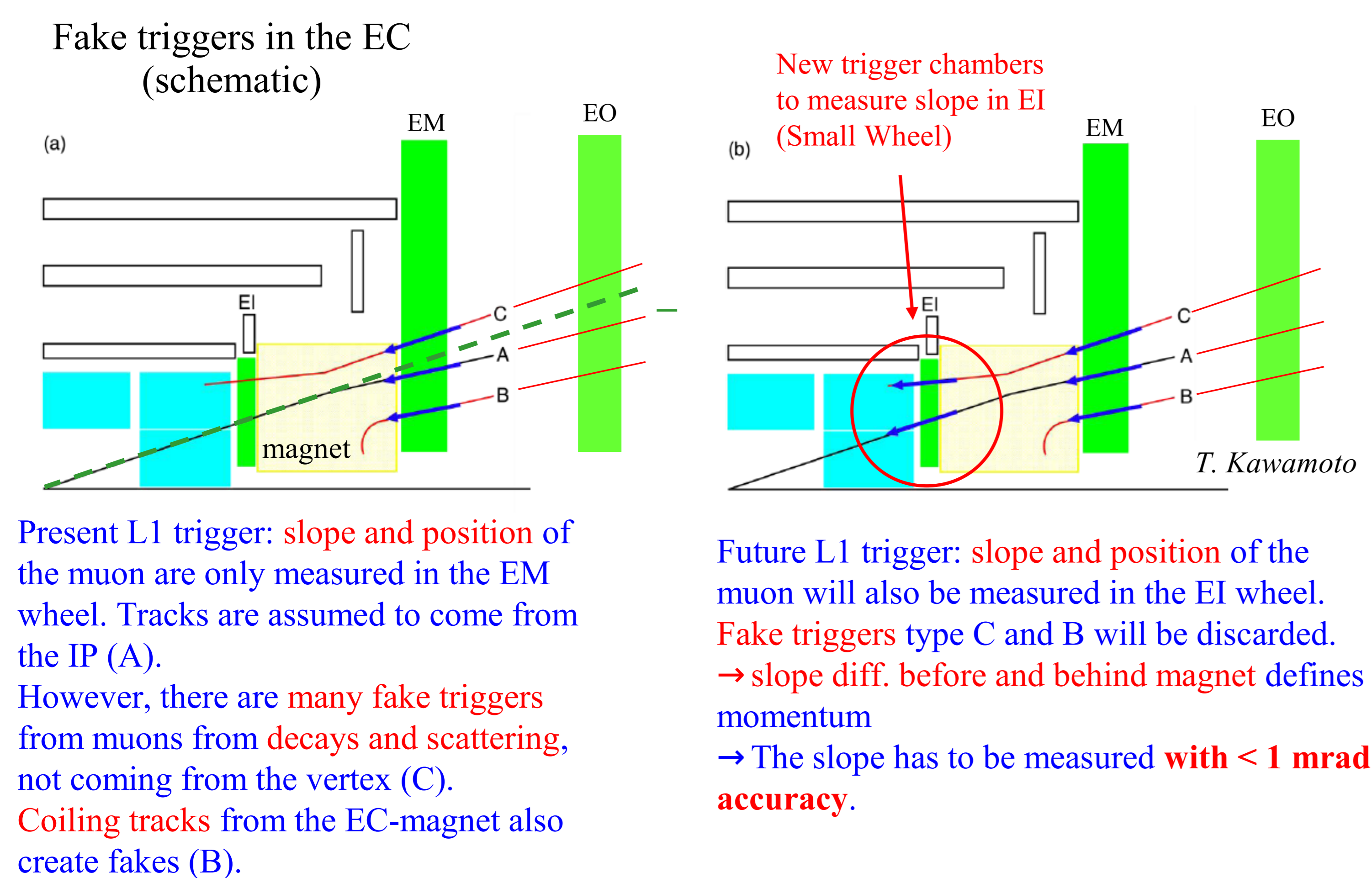

## Architecture of MDT Readout

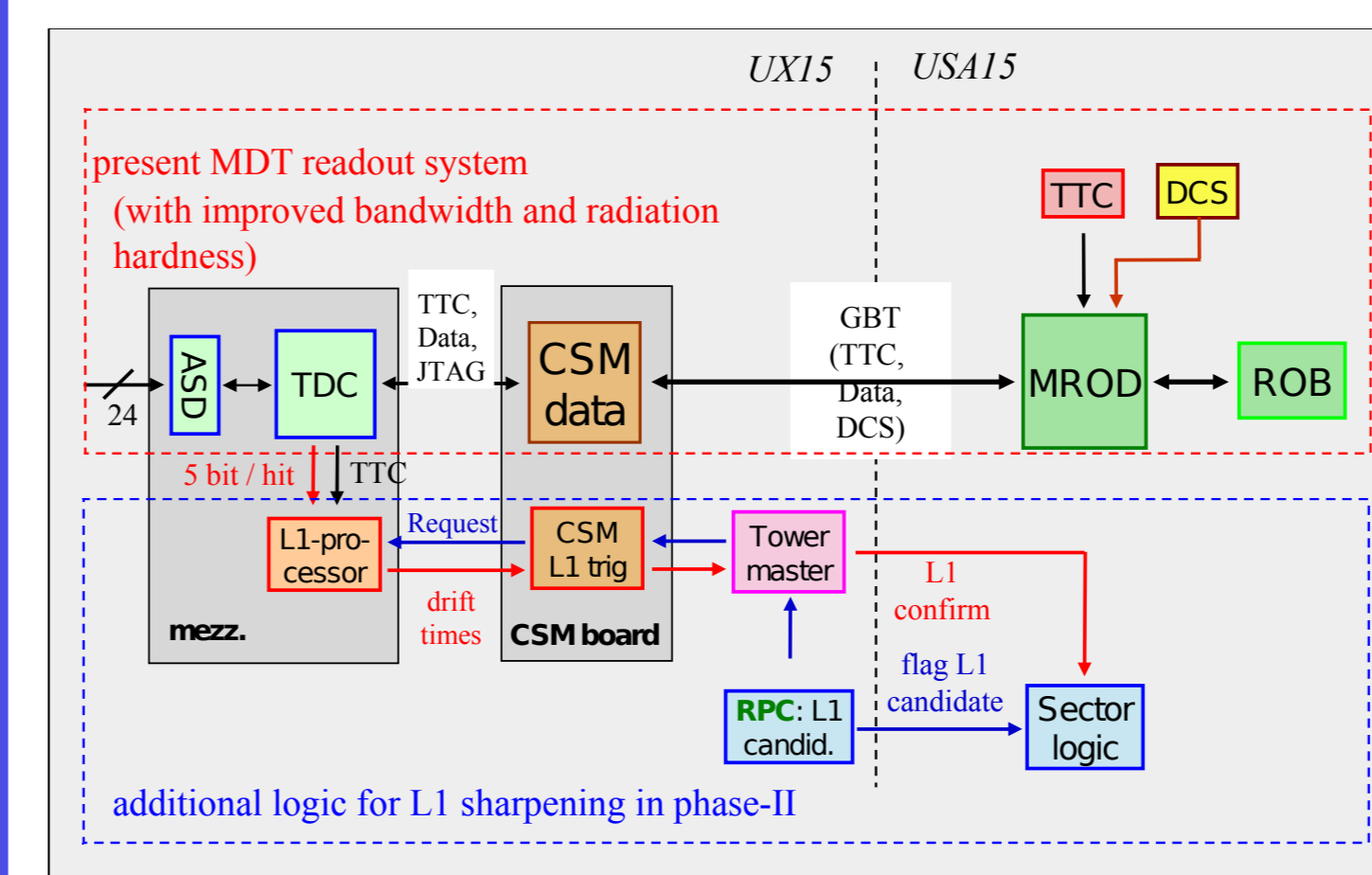

## Fast and Standard Readout

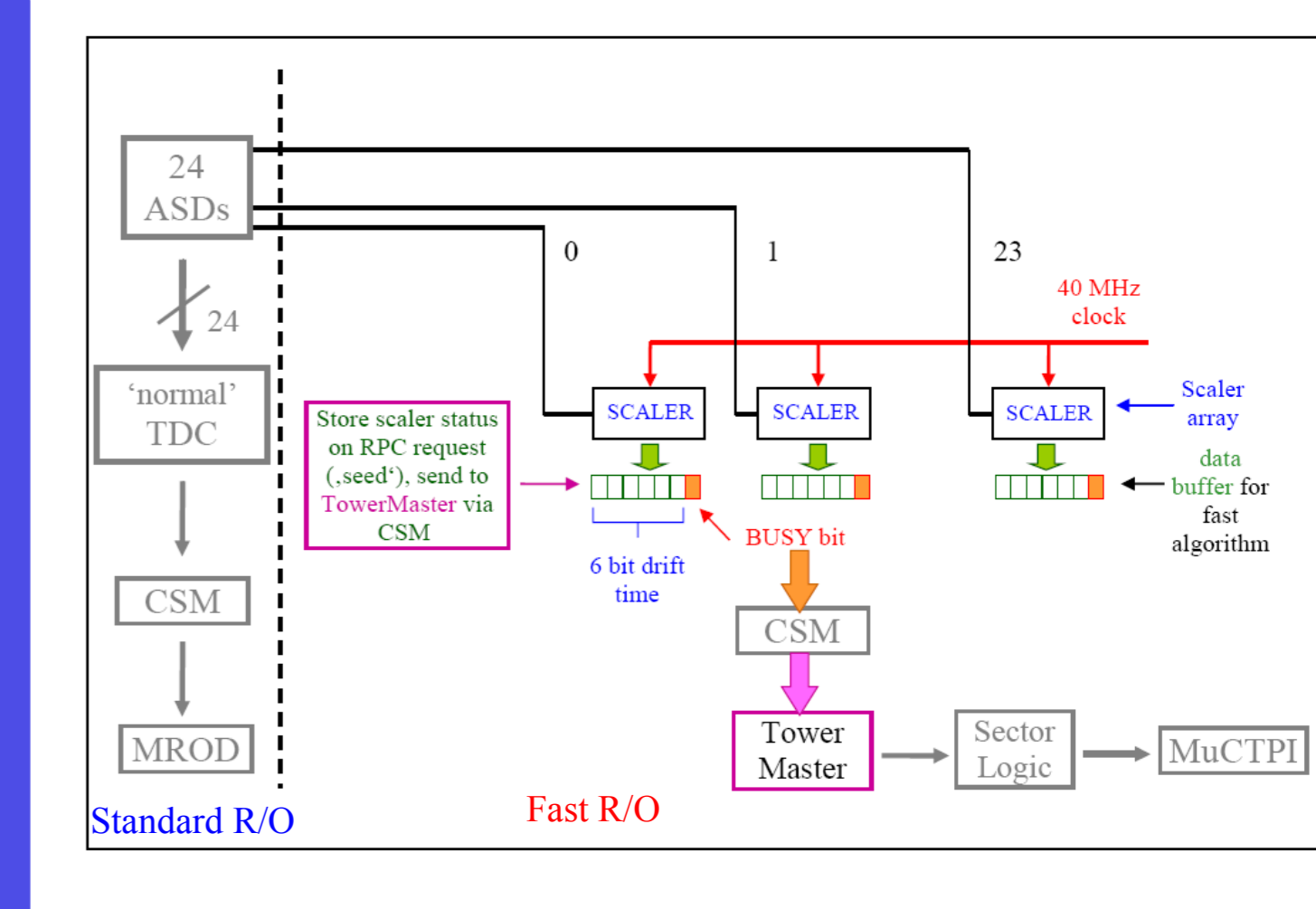

## Mezz. Prototype with new ASD

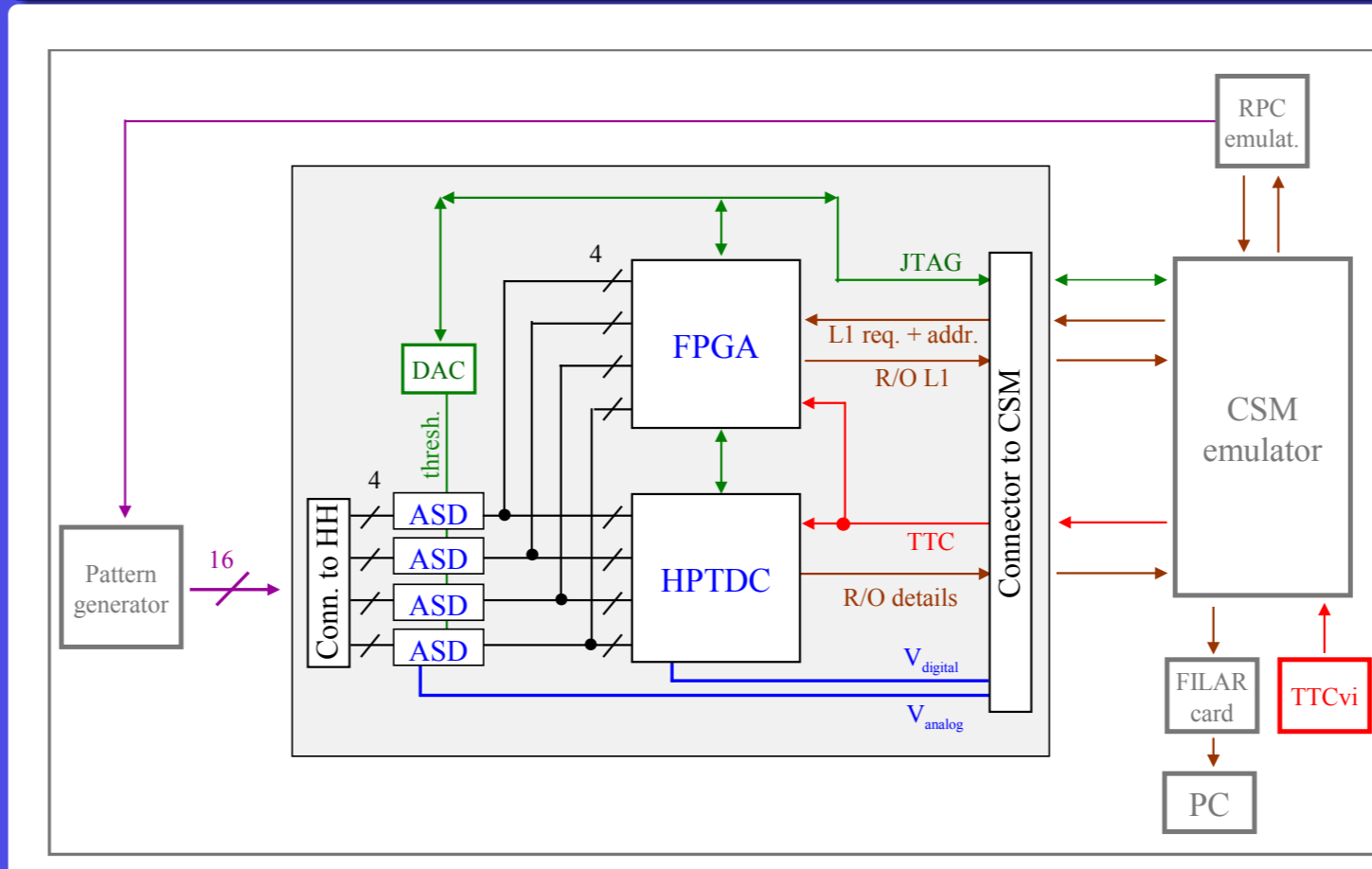

## Analog Performance of ASD2 vs. 1

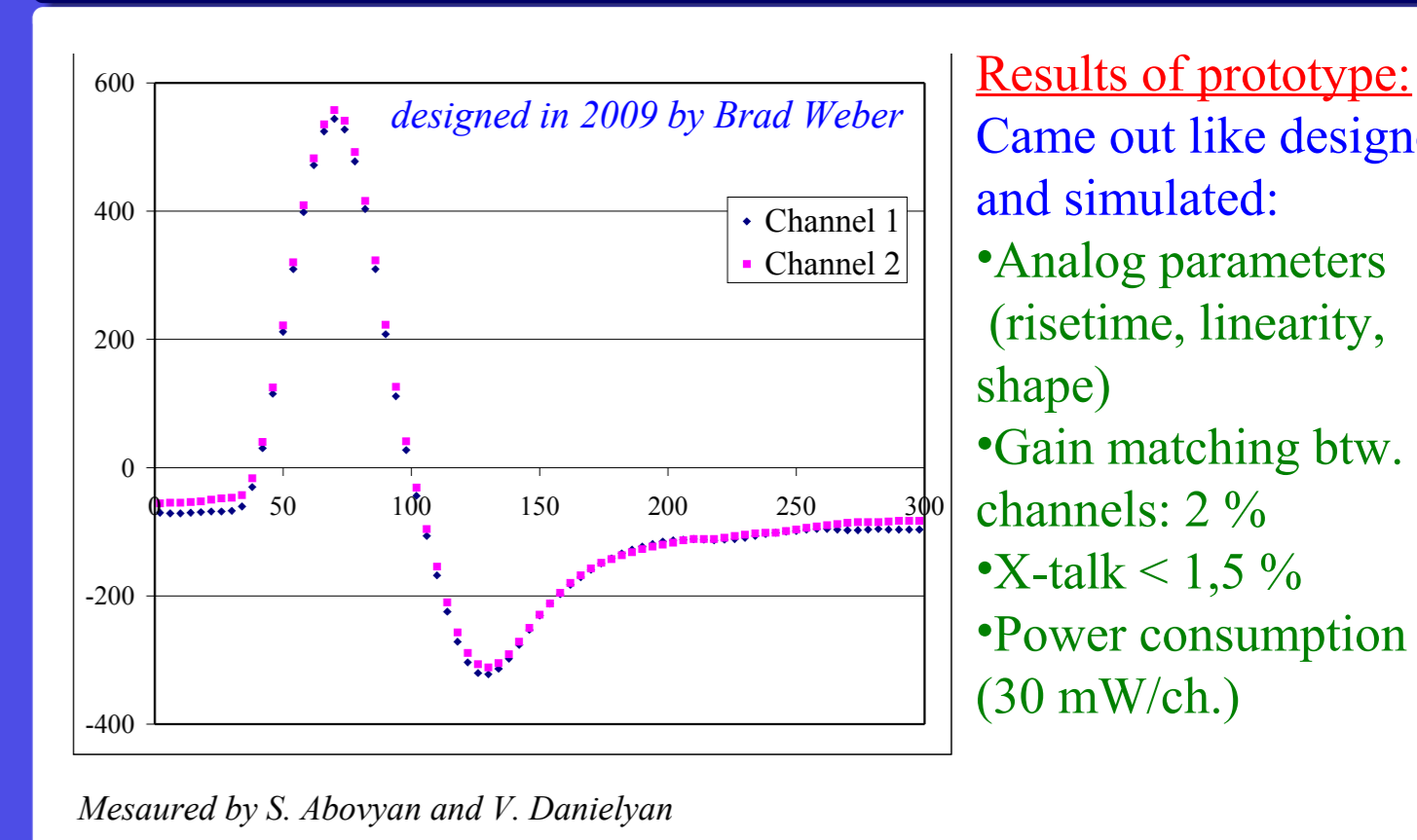

## Conclusions

- The selectivity of the ATLAS L1 muon trigger needs to be improved for higher luminosities.
- Longer latency in phase-2 of  $\gtrsim 6.4 \mu\text{s}$  allows to use MDT information in L1.

- The proposed scheme does not need new trigger chambers to be installed.
- New radiation hard MDT readout electronics with L1 functionality are being developed and tested.